

■ High Efficiency

■ High Precision

■ High Stability

Programmable DC Electronic Load

»» Application Guide

Programmable DC Electronic Load

Programmable DC Electronic Load



(3U)3400W~5600W



(4U)6600W



(7U)8800W~13200W



(10U)15400W~19800W



(13U)22000W~26400W

Voltage	Input		Model	Size	Resolution		Accuracy		Flippable Front Panel	Certificates
	Current	Power			Voltage	Current	Voltage	Current		
200V	370A	3400W	EL200VDC3400W	3U ¹	0.1mV	0.5mA	0.015%+0.015%F.S.	0.04%+0.04%F.S.	NO	CE
	480A	4400W	EL200VDC4400W		0.1mV	0.5mA				
	610A	5600W	EL200VDC5600W		0.1mV	0.5mA				
	720A	6600W	EL200VDC6600W	4U ²	0.1mV	0.5mA			YES	
	960A	8800W	EL200VDC8800W	7U ³	0.1mV	1mA				
	1200A	11000W	EL200VDC11000W		0.1mV	1mA				
	1440A	13200W	EL200VDC13200W		0.1mV	1mA				
	1680A	15400W	EL200VDC15400W	10U ⁴	0.1mV	2mA				
	1920A	17600W	EL200VDC17600W		0.1mV	2mA				
	2160A	19800W	EL200VDC19800W		0.1mV	2mA				
	2400A	22000W	EL200VDC22000W	13U ⁵	0.1mV	4mA				
	2640A	24200W	EL200VDC24200W		0.1mV	4mA				
2880A	26400W	EL200VDC26400W	0.1mV		4mA					
600V	250A	3400W	EL600VDC3400W	3U ¹	0.5mV	0.4mA	0.015%+0.015%F.S.	0.04%+0.04%F.S.	NO	CE
	320A	4400W	EL600VDC4400W		0.5mV	0.4mA				
	410A	5600W	EL600VDC5600W		0.5mV	0.4mA				
	480A	6600W	EL600VDC6600W	4U ²	0.5mV	0.5mA			YES	
	640A	8800W	EL600VDC8800W	7U ³	0.5mV	0.5mA				
	800A	11000W	EL600VDC11000W		0.5mV	1mA				
	960A	13200W	EL600VDC13200W		0.5mV	1mA				
	1120A	15400W	EL600VDC15400W	10U ⁴	0.5mV	1mA				
	1280A	17600W	EL600VDC17600W		0.5mV	1mA				
	1440A	19800W	EL600VDC19800W		0.5mV	2mA				
	1600A	22000W	EL600VDC22000W	13U ⁵	0.5mV	2mA				
	1760A	24200W	EL600VDC24200W		0.5mV	2mA				
1920A	26400W	EL600VDC26400W	0.5mV		2mA					
1200V	130A	3400W	EL1200VDC3400W	3U ¹	1mV	0.2mA	0.015%+0.015%F.S.	0.04%+0.06%F.S.	NO	CE
	160A	4400W	EL1200VDC4400W		1mV	0.2mA				
	210A	5600W	EL1200VDC5600W		1mV	0.2mA				
	240A	6600W	EL1200VDC6600W	4U ²	1mV	0.2mA			YES	
	320A	8800W	EL1200VDC8800W	7U ³	1mV	0.4mA				
	400A	11000W	EL1200VDC11000W		1mV	0.4mA				
	480A	13200W	EL1200VDC13200W		1mV	0.4mA				
	560A	15400W	EL1200VDC15400W	10U ⁴	1mV	0.5mA				
	640A	17600W	EL1200VDC17600W		1mV	0.5mA				
	720A	19800W	EL1200VDC19800W		1mV	0.5mA				
	800A	22000W	EL1200VDC22000W	13U ⁵	1mV	1mA				
	880A	24200W	EL1200VDC24200W		1mV	1mA				
960A	26400W	EL1200VDC26400W	1mV		1mA					

Programmable DC Electronic Load

Dimensions & Weight



❶ 133x423x610mm & 32.5kg



❷ 177x423x610mm & 37.5kg



❸ 310x423x670mm & 72.5kg



❹ 442x423x670mm & 110kg



❺ 575x423x670mm & 145kg

Optional Information

(1) LAN & GPIB interface card & cables



Features

- Flippable front panel and color touch screen allow convenient access and operation.
- Provides four kinds of basic working mode such as CV/CC/CR/CP, and CV+CC/CV+CR/CR+CC complex operating modes.
- Adjustable current slew rate, adjustable CV loop speed.
- Ultra high precision voltage & current measurement.
- OCP/OPP testing function.
- 50kHz high-speed CC/CR dynamic mode.
- 500kHz high-speed voltage and current sampling rate.
- Timing & discharging measurement for batteries.
- Short circuit test mode.
- Auto mode function provides an easy way to do complicated test.
- Dynamic frequency sweep function for determining worst case voltage peaks.*
- Non linear load mode function makes the simulated loading current more realistic.*
- Supports external analog control function*
- V-monitor/I-monitor.
- LED load simulation function.
- Full protection: OCP, OPP, OTP, over voltage and reverse alarm.
- Up to 20 units master/slave parallel control.
- Front panel USB interface supports data import and export.
- SCPI language and standard rack size make it ideal for ATE System integration.
- Smart fan control with lower noise and better for environment.
- Multi versions to meet the cost performance and different applications.

* Only professional Electronic Load units support these functions.

Programmable DC Electronic Load

Panel Introduction

Front Panel Description

- 1 Power switch
- 2 USB host, for data import and export
- 3 Color touch screen
- 4 Numeric keys and function keys
- 5 Function keys and multifunction keys
- 6 Enter key and arrow keys
- 7 Push-on knob, for editing parameter and moving the location of cursor
- 8 Ventilation holes
- 9 Stylus

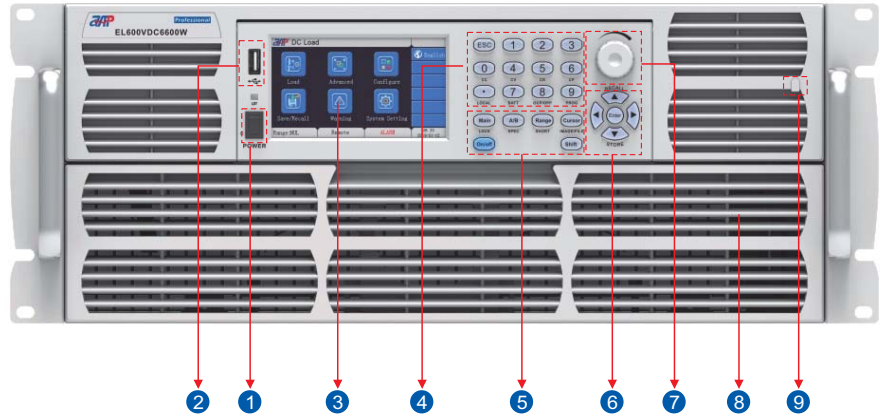

Rear Panel Description

- 1 Load positive/negative terminal
- 2 Remote sense connections
- 3 System Bus, for mater/slave system data transmission
- 4 RS485/RS232/USB communication Interface (standard), LAN&GPIB communication Interface (optional)*
- 5 External TTL/Analog control Interface
- 6 V-monitor/I-monitor
- 7 AC input connector
- 8 Ventilation holes

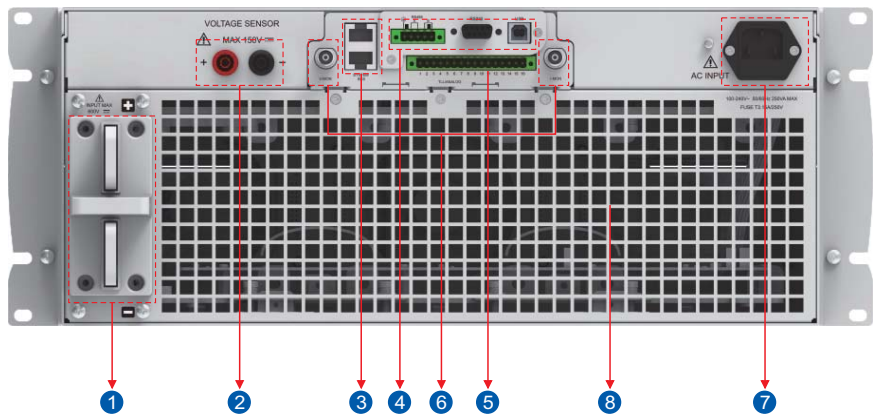

* When LAN&GPIB interface card selected it will be installed here instead of RS485/RS232/USB interface card.

Function Introduction

Flippable Front Panel and Color Touch Screen

This series programmable DC electronic load is equipped with flippable front panel for 4U, 7U, 10U and 13U height models. Together with a large color touch screen provides simple and fast operation for customer. Real-time update of display input data, status and graphical display makes it more intuitive.

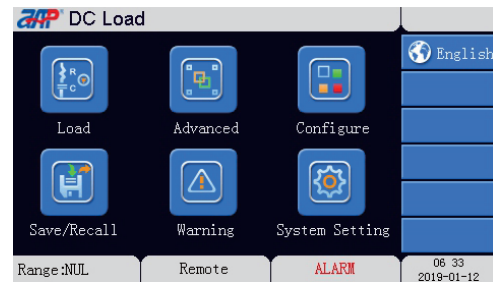

Multiple Operating Mode

Basic Operating Mode

This series programmable DC electronic load provides four kinds of basic operating mode including CV (constant voltage), CC (constant current), CR (constant resistance), CP (constant power), to satisfy a wide range of test requirements.

CC Mode

1. Load regulation test of DC power supply
2. Discharge time and life test for battery
3. Fuel cells test
4. Loading test for DC motor

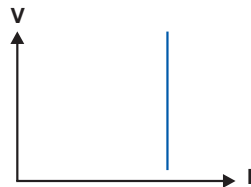

CV Mode

1. Charging station test
2. Current limit testing for Fold back type power supply
3. Fuel cells test
4. Current source test



CR Mode

1. Slow start test for communication power supply
2. LED driver test
3. Loading test for automobile temperature controller

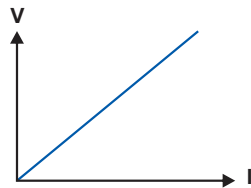

CP Mode

1. Testing for constant power type power supply
2. Capacity and life test for battery

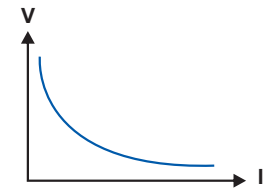

Programmable DC Electronic Load

Complex Operating Mode

The CV+CC mode can be applied to the load simulation battery and test the charging station or the car charger.

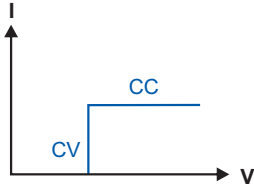

The CV+CR mode can be used to simulate the dynamic characteristics of LED.

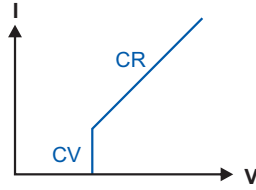

The CR+CC mode is suitable for power on testing.

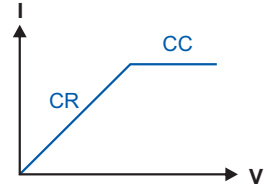

Adjustable CV Loop Speed

This series electronic load supports CV loop response speed setting to FAST, NORMAL or SLOW to satisfy different test requirements. This function may avoid the inaccurate measurement or testing fail caused by the response speed mismatch between the load and the power supply, which is possible to improve test efficiency and reduce costs on the equipments, time and expenses.

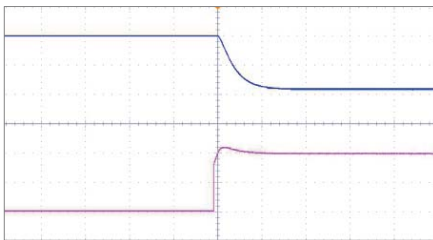

Slow speed of CV loop

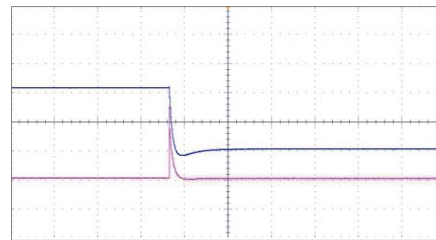

Normal speed of CV loop

Dynamic Load

This series electronic load can be switched quickly between different values in the same operating mode, including CC dynamic mode, CV dynamic mode, CR dynamic mode and CP dynamic mode, CC/CR high speed dynamic mode up to 50kHz.

This function is suitable for transient test of power supply, test of battery protection characteristic and battery pulse charging etc.

Dynamic mode test has continuous mode, pulse mode and toggle mode.

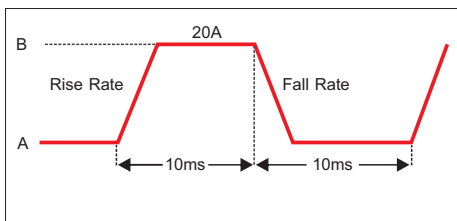

Continuous Mode

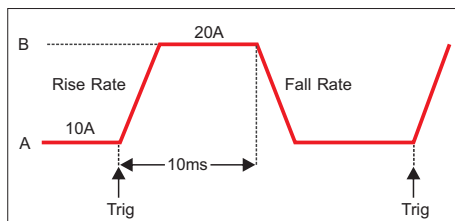

Pulse Mode

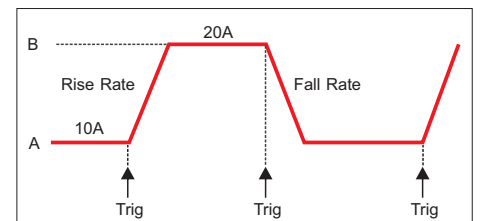

Toggle Mode

Sine Wave Dynamic Load

This series electronic load supports sine wave loading function which allows to load sine wave, can be used for impedance analysis test of fuel cells.

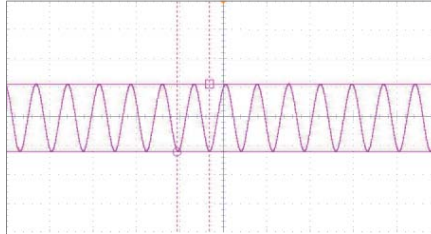

Dynamic Frequency Sweep Function

This series electronic load provides a unique constant current dynamic sweep to use frequency conversion to find out the UUT voltage of worst case.

This CC dynamic sweep allows the user to edit two load levels, start frequency, end frequency, step frequency, dwell etc. The sampling rate is up to 500kHz, which make it can simulate different loading conditions for most test requirements.

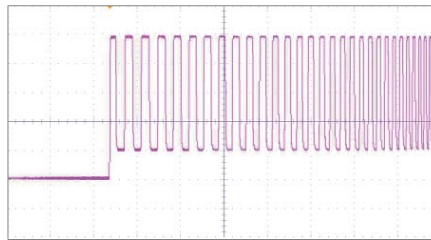

Battery Discharge Test

This series electronic load has battery discharge function, and can perform discharge test under CC, CR or CP mode. The DC load can set end voltage or time to stop loading correctly and make sure the battery is not damaged due to over discharge. The user can set stop conditions, whenever met any condition, the load will stop loading and counting automatically. During the test, users can observe battery's voltage, discharging time and already-discharged-capacity.

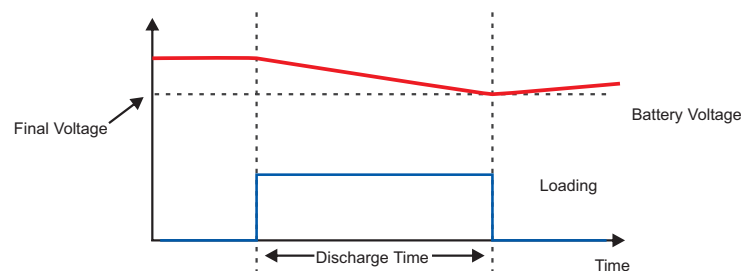

Programmable DC Electronic Load

Auto Mode

This mode allows automatically switches among CV, CR, CC and CP modes. It is suitable for lithium ion battery charger testing to get a complete V-I charging curve. This flexible auto mode also enormously improve test efficiency.

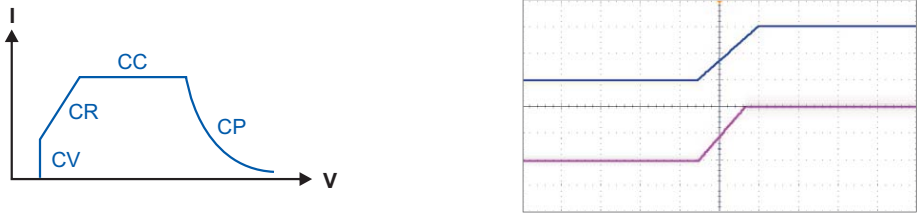

OCP/OPP Tests

This series electronic load provides OCP and OPP modes are mainly applied in over-current and over-power points tests. After the testing the load can automatically judge the test result according to the set specifications. Take OPP testing as example, the OPP provides ramped up power for the load to test the UUT voltage whether has reached trigger voltage level and to judge if the protection is acting normally or not.

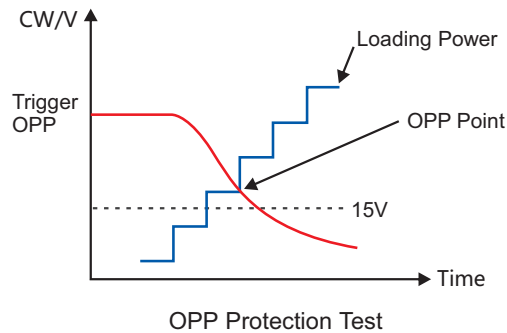

List Mode

The list function allows user to create waveform files to automatically simulate various complicated loading conditions. The list mode has 10 files, by editing operating mode (including CC, CV, CR ,CP, Short and ON/OFF), repeat times, total steps, setting value of each step and step time etc. This function can be applied to the testing of output characteristic and stability for power supply.

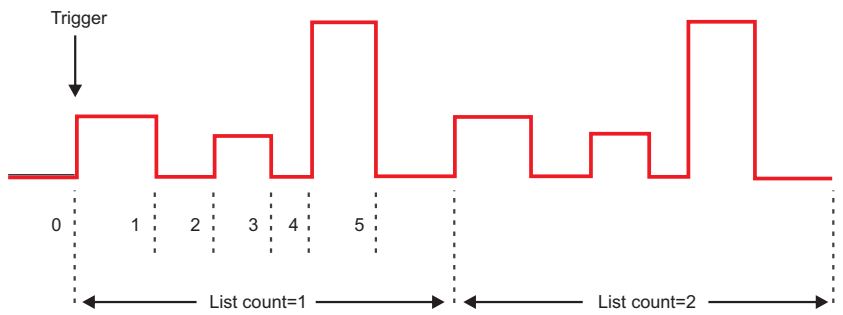

Programmable DC Electronic Load

Master/Slave Control

This series electronic load provides the user with Master/slave mode, supports parallel connection under different power and same voltage and dynamically synchronized. In Master/slave mode, the user only need to control the master one, the load current will be automatically calculated and downloaded to the slave loads. The Master/slave mode greatly simplifies the operation when increased power is needed.

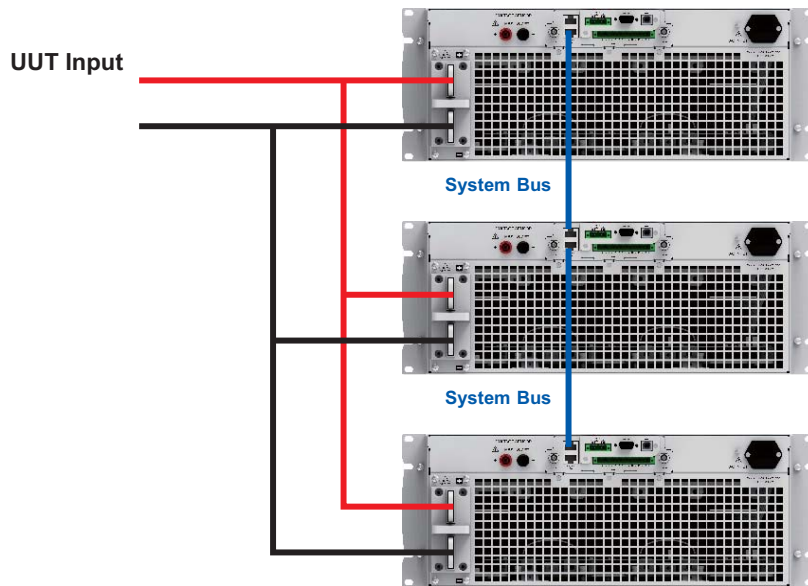

External Control and Current/Voltage Monitoring

This series electronic load has analog control interface to control the input voltage and current. The external signal 0 to 10V controls the sinking condition from 0 to full scale. Using the external control mode can simulate arbitrary waveform which is ideal for industrial control requirement.

The 0 to 10V analog output signal of V-MON/I-MON terminals represent input to which the terminals belong from 0 to full range. An external voltmeter or oscilloscope can be connected to display input voltage/current change.

Applications



New energy



Automotive electronics



Electronic component



Power supply



Battery charge/discharge test



ATE systems



R/D design verification/quality assurance



Factory production online test

APM Technologies (Dongguan) Co., Ltd

Add: #7, Link Information Industry Park, Shuilianshan Road,
Nancheng, Dongguan, Guangdong, China

Tel: +86 769-2202 8588 ext:2892 Fax: +86 769-2202 6771

E-mail: overseas@apmtech.cn Web: en.apmtech.cn



Scan the QR code for more information