



High Power Programmable DC Power Supply

- High Efficiency
- High Precision
- High Stability

[Application Guide](#)

High Power Programmable DC Power Supply

High Power Programmable DC Power Supply



(3U)6000W~18000W



(6U)24000W~36000W

Rated Voltage	Output		Model	Size	Ripple		Response		Internal Resistance
	Rated Current	Rated Power			Voltage	Current	Voltage increase	Voltage Drop	
80V	200A	6000W	SP80VDC6000W	3U ¹	<180mVpp, <15mVrms	<100mArms	<15ms (No Load) <100ms (Full Load)	<650ms (No Load) <10ms (Full Load)	0~14Ω
	400A	12000W	SP80VDC12000W	3U ²	<288mVpp, <23mVrms	<200mArms			0~7Ω
	600A	18000W	SP80VDC18000W	3U ³	<320mVpp, <25mVrms	<300mArms			0~5Ω
	800A	24000W	SP80VDC24000W	6U ⁴	<320mVpp, <25mVrms	<360mArms			0~3.5Ω
	1000A	30000W	SP80VDC30000W	6U ⁵	<320mVpp, <25mVrms	<450mArms			0~2.8Ω
	1200A	36000W	SP80VDC36000W	6U ⁶	<320mVpp, <25mVrms	<540mArms			0~2.3Ω
165V	200A	12000W	SP165VDC12000W	3U ²	<580mVpp, <50mVrms	<100mArms	<15ms (No Load) <100ms (Full Load)	<650ms (No Load) <10ms (Full Load)	0~24.8Ω
	400A	24000W	SP165VDC24000W	6U ⁴	<580mVpp, <50mVrms	<200mArms			0~12.4Ω
250V	200A	18000W	SP250VDC18000W	3U ³	<550mVpp, <50mVrms	<100mArms	<15ms (No Load) <100ms (Full Load)	<650ms (No Load) <10ms (Full Load)	0~37.5Ω
	400A	36000W	SP250VDC36000W	6U ⁶	<550mVpp, <50mVrms	<200mArms			0~18.8Ω

High Power Programmable DC Power Supply

Dimensions & Weight



① 483x132x800mm & 23kg



② 483x132x800mm & 34kg



③ 483x132x800mm & 45kg



④ 483x265x800mm & 67.6kg



⑤ 483x265x800mm & 78.8kg



⑥ 483x265x800mm & 90kg

Optional Information

(1) US models, input voltage range: 187~253Vac*

(2) European models, input voltage range: 340~460Vac*

(3) Continuous source & sink function*

(4) GPIB & LAN communication card & cables

(5) CAN communication card

(6) TTL/Analog control card



(4)



(5)

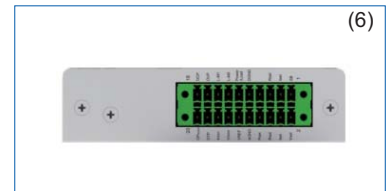

(6)

* These options must be specified at the time of order as they are installed at the factory prior to shipment.

Features

- Large color touch screen with intuitive interface provides an excellent intuition operational experience.
- 3-phase input voltage meets worldwide power distribution regulation, AC mains 187~253Vac/340~460Vac for optional.
- Constant voltage (CV), constant current (CC) and constant power (CP) operation mode, CC or CV working priority setting.
- Adjustable voltage/current slew rate.
- DDS arbitrary function generator.*
- Solar panel I-V curve simulation function.*
- Smart 3-stage charging algorithm simulation.*
- Battery simulator function.*
- Continuous source & sink function, with APM DC E-load to expand loading capability (optional).
- List/ Step mode programming.
- TTL/Analog control and monitoring.
- Built-in standard automotive power network voltage curves.*
- Full protection: OVP, OCP, OPP and OTP protection.
- Supports master-slave mode, paralleling up to 16 units.
- Supports SCPI commands, provides web GUI function.

* Only professional version units support these functions.

High Power Programmable DC Power Supply

Supported Functions Professional Version Only

No.	Description	Application
1	DDS arbitrary function generator	Includes a true function generator, built-in typical functions, supports complex waveforms creation, used for testing purposes in development and production
2	Solar panel I-V curve simulation function	Users can set the parameters to simulate I-V curve characteristic output
3	Smart 3-stage charging algorithm simulation	Commonly used charging curve simulation
4	Battery simulator function	Truly simulate the changes of internal resistance of battery in charging and discharging test.
5	Built-in standard automotive power network voltage curves	Users can recall the built-in standard curve to do the DUT performance test directly.

Panel Introduction

Front Panel Description

- ① Power switch
- ② Color touch screen
- ③ Selection soft keys
- ④ Voltage/Current & Power knob
- ⑤ Numeric and functional keys
- ⑥ USB port, for data transfers and firmware upgrading
- ⑦ Stylus

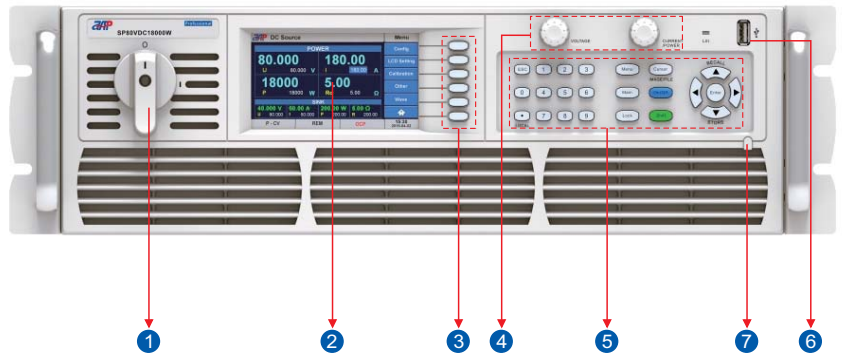

Rear Panel Description

- ① RS485/RS232/USB communication interface (standard), LAN&GPIB communication interface (optional), CAN communication interface (optional)*
- ② External TTL/Analog control interface.
- ③ System Bus, for master/slave system data transmission
- ④ Termination resistor CAN-R
- ⑤ Vs+/Vs- Remote sense connections
- ⑥ DC output negative/positive terminal
- ⑦ AC mains input connector

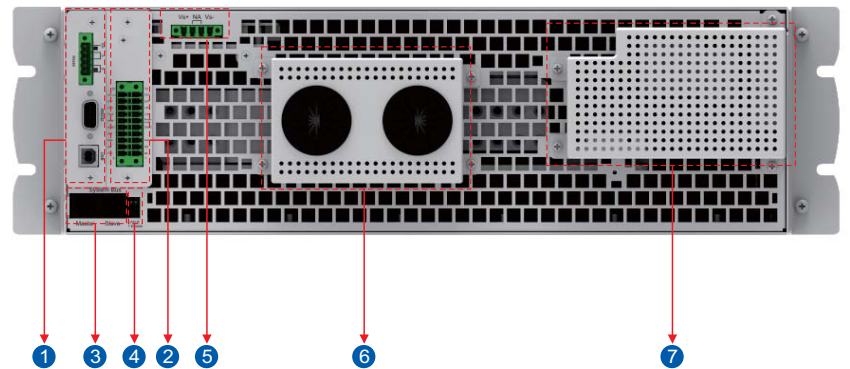

* These interface option installs in place of the standard RS485/RS232/USB interfaces, occupies the same physical slot.

High Power Programmable DC Power Supply

Function Introduction

Graphical User Interface

The large color touch screen provides simple and fast operation for customers, real-time update of display output data and power status. The actual values are displayed with bigger characters, so they can be read from a large distance.

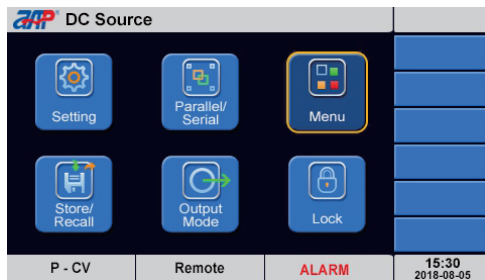

Wide Input Voltage Range & High Power Density

3-phase input voltage range 187~460Vac meets worldwide power distribution regulation. 36kW/6U high density, higher efficiency, lower ripple and fast response make it ideal for test requirements in different periods of different applications. This series power supply can have from one to three internal 6kW power blocks, each of which is connected across a separate phase of the 3-phase AC mains. The following figures illustrate how to install three 6kW units or three 12kW to obtain a balanced current draw on the 3-phase AC mains.

Phase balancing connection for three 6kW units

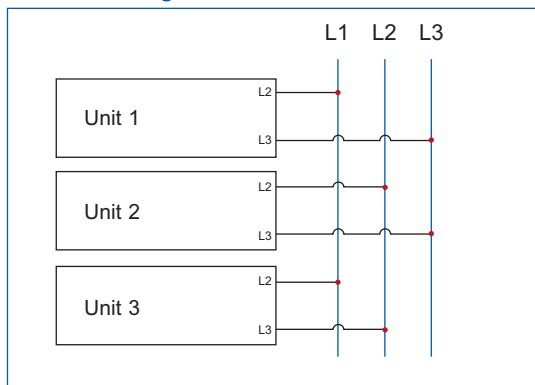

Phase balancing connection for three 12kW units

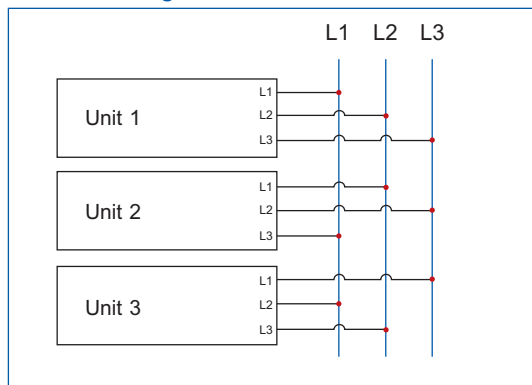

CC & CV Priority

This series power supply provides CC/CV priority function allows the user to select suitable mode correspond to test requirement, let the output be voltage high speed or current no overshoot mode. Below shows an application of CC priority to avoid current overshoot during LED test.

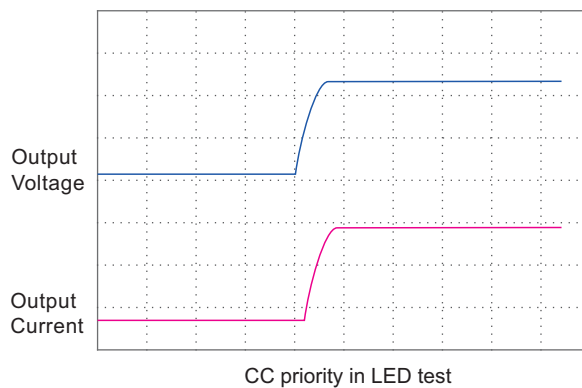
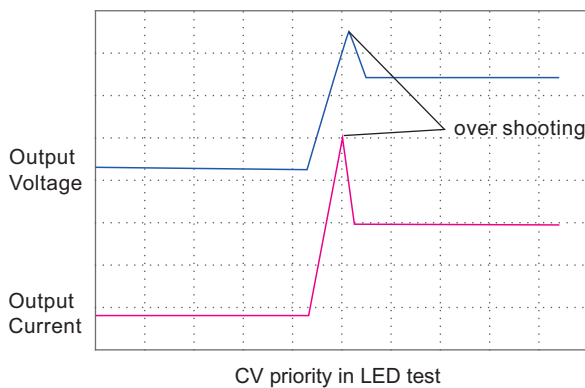

High Power Programmable DC Power Supply

Adjustable Voltage/Current Slew Rate

This series power supply provides adjustable rise and fall time setting for voltage and current. Adjustable time range 1ms~24h.

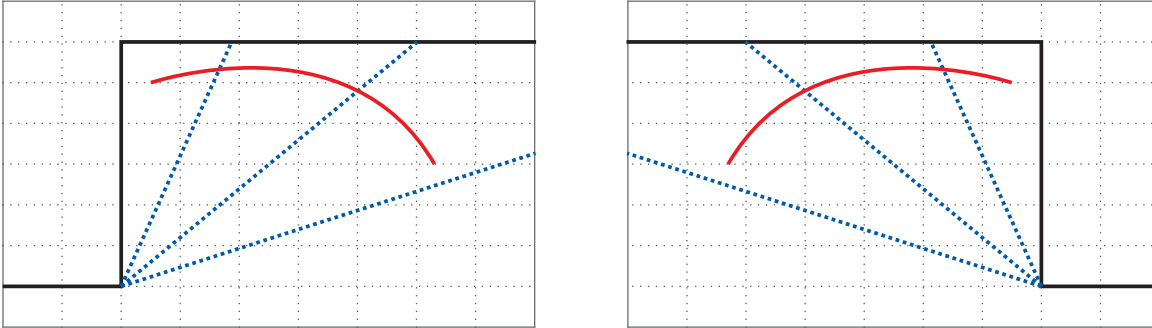

* Actual ramp down time may shift refer to load.

DDS Arbitrary Function Generator

This series power supply includes a true function generator which can generate typical functions as displayed below, convenient for editing or directly recall. Additional to the standard functions, this arbitrary generator is accessible for the creation and execution of complex sets of functions, which is can be used for testing purposes in development and production.

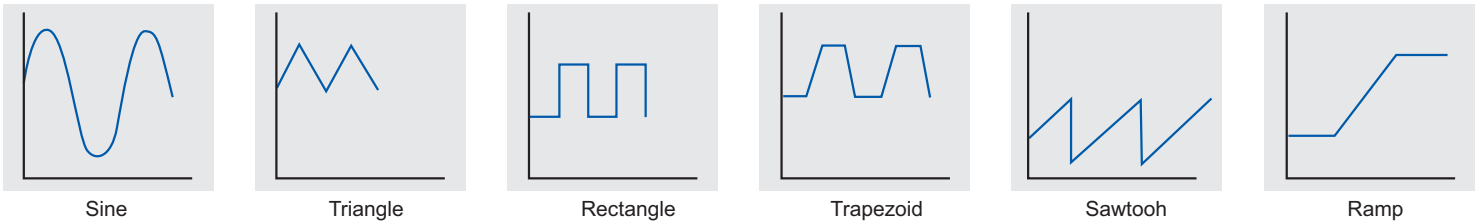

Built-in Standard Automotive Power Network Voltage Curves

This series power supply has built-in German DIN40839 standard voltage curve for the automotive power network and the international standard ISO-16750-2 pulse waveform. The fast rise/fall response time together with arbitrary function generate ability make it can truly simulate the influence on the performance of automotive electronic equipment under different test conditions, is the preferred power testing instrument in the automotive electronics industry.

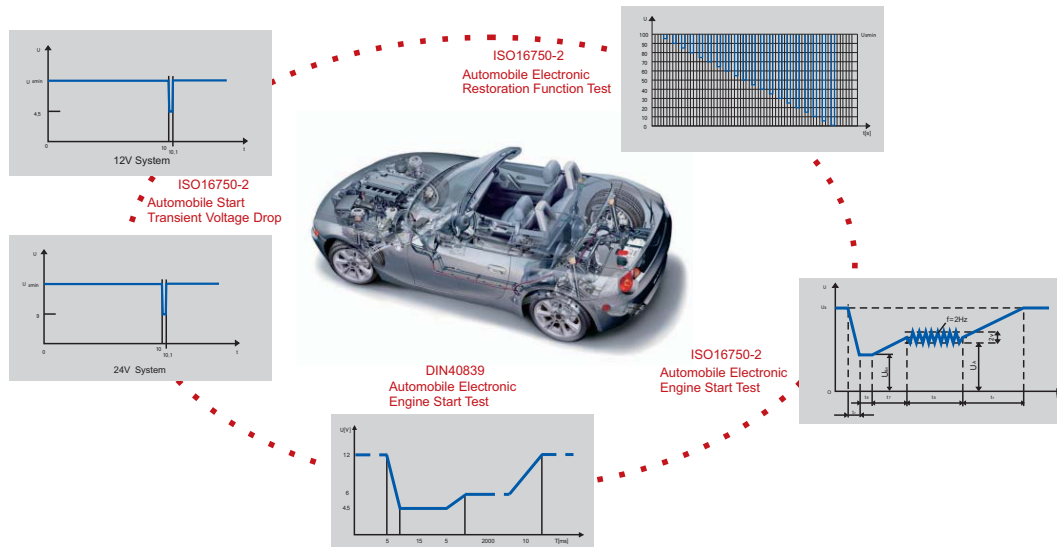

High Power Programmable DC Power Supply

Solar Panel I-V Curve Simulation Function

The power supply provides a unique feature to simulate the output characteristics of a solar array including Curve Mode, User-defined Mode and SAS Mode. With Curve mode, only need to set four parameters to simulate the solar array I-V curve. With User-defined mode, user can shape an I-V curve by entering up to 4096 points to simulate dynamic cloud cover effect which is useful for MPPT performance evaluation on PV inverter device. With built-in SAS mode, user can set the parameters to simulate I-V curve characteristic output and generate reports.

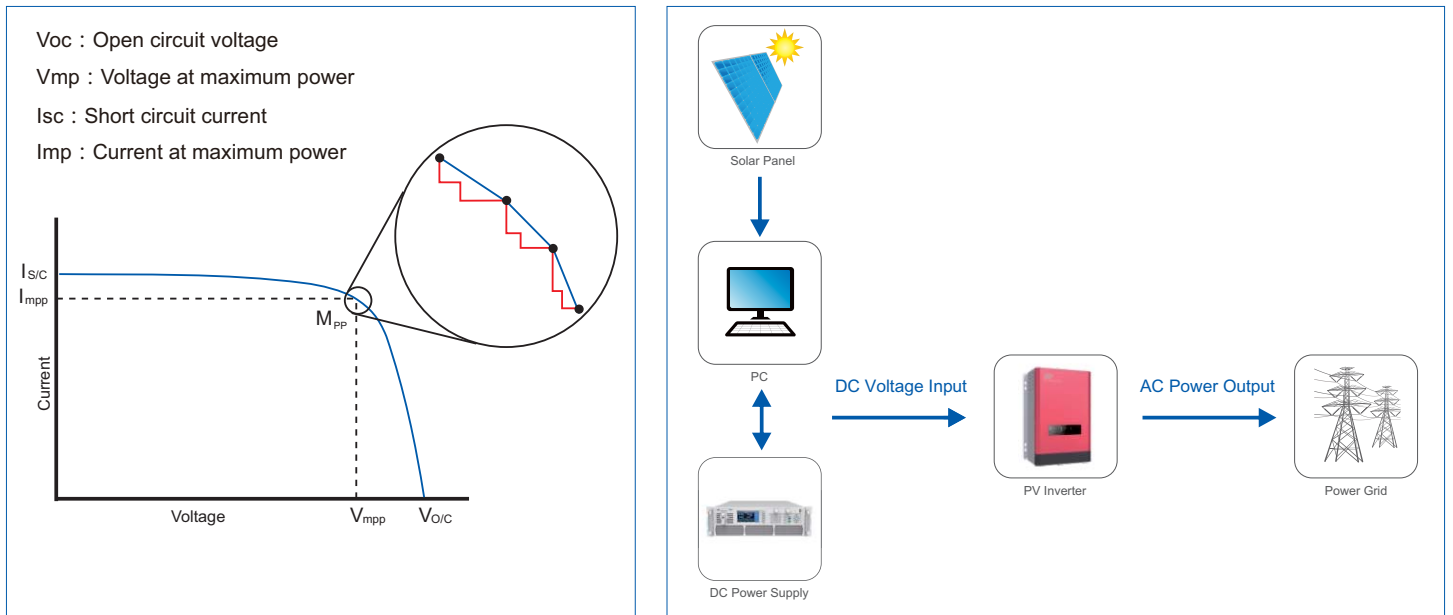

Continuous Source & Sink Function (optional)

Additionally to the Source mode, this series power supply is equipped with electronic load, also called Sink mode, to absorb power, that enables it work as a two-quadrant power supply. The switchover between these two operating modes occurs without interruption and time loss, thus avoiding overshoot of voltage or current. As a power supply, CV, CC, CP modes are available. As an electronic load, CV, CC, CP and CR mode are available. Thus making it suitable for inductive load and capacitive load testing.

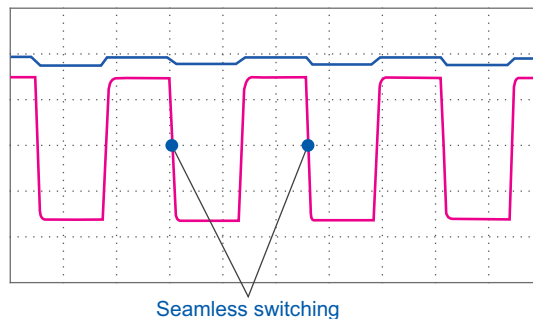

High Power Programmable DC Power Supply

With APM DC E-load To Expand Loading Capability

If a large fast current sinking capability is required, the user can choose APM programmable electric DC loads as well. A power supply can connect and control three DC loads at the same time through CAN communication to realize a rapid response system. Meeting demanding requirements of high power discharging test.

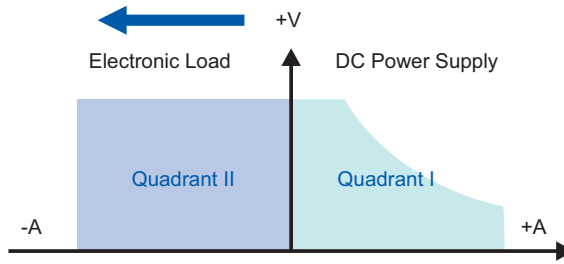

Smart 3-stage Charging Algorithm Simulation

This series power supply adopts 3-stage charging algorithm, built-in charging curves which is suitable for the commonly known types of batteries on the market. Users can directly recall the default curves or change the switching conditions at different charging stage according to the test requirement. Through the internal design, it improved and optimized hardware improvements, the current passing from the battery to power supply will be less than 10mA at any battery voltage when turn off the power supply. Thus avoid battery capacity loss, even when there is no anti reverse irrigation equipment.

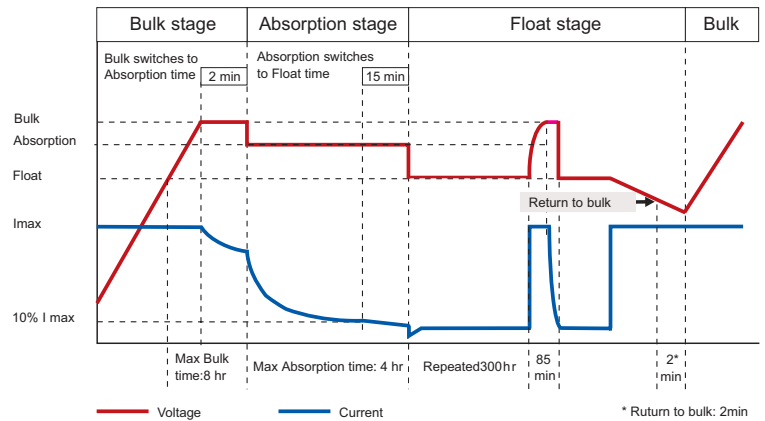
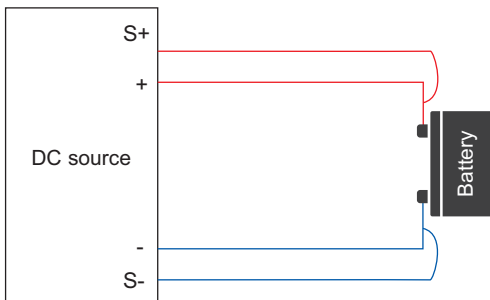

High Power Programmable DC Power Supply

Battery Simulator Function

This series power supply built-in typical battery internal resistance curves and discharging curves can easily simulate battery behavior in real-case.

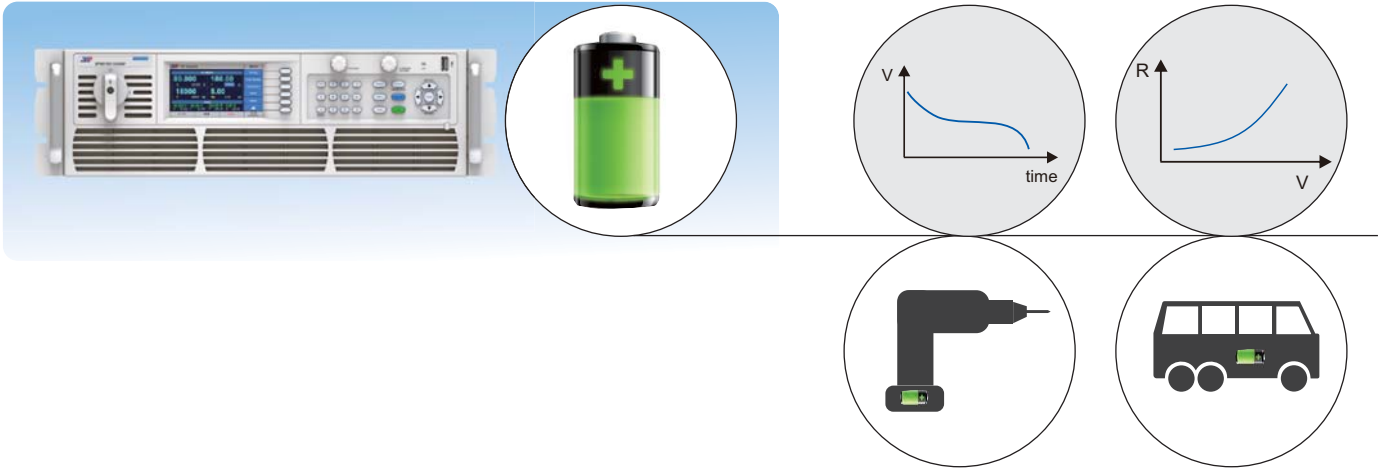

List/Program/Step Mode Programming

This series power supply provides List/Program/Step modes for output waveform programming. Users can edit the voltage/current value & the time of each step in advance and provide the power supply with a trigger signal. Then the preset sequences / waveform will be executed automatically according to the defined files. Sequence mode supports link between multiple files, the user can set the repeat times of each file and the total repeat times of the complete sequence file.

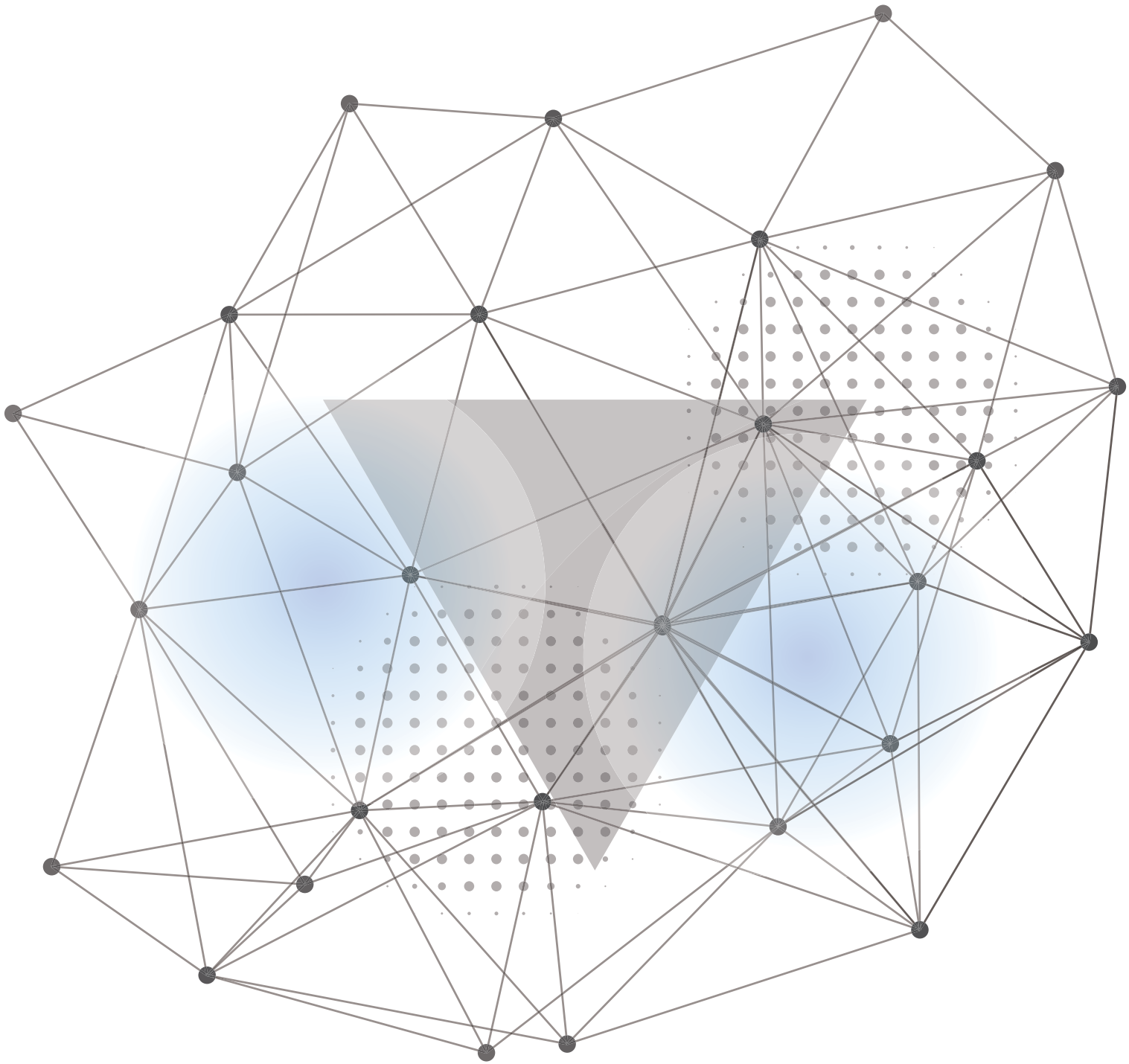

APM Technologies (Dongguan) Co., Ltd

Add: #7, Link Information Industry Park, Shuilianshan Road,
Nancheng, Dongguan, Guangdong, China

Tel: +86 769-2202 8588 ext:2892 Fax: +86 769-2202 6771

E-mail: overseas@apmtech.cn Web: en.apmtech.cn



Scan the QR code for more information