

PROGRAMMABLE POWER SUPPLY

DC

WIDE RANGE DC POWER SUPPLY SERIES



■ High Efficiency

■ High Precision

■ High Stability

PROGRAMMABLE DC POWER SUPPLY

Wide-range Programmable DC power Supply



600W~1600W



1000W~4000W

Output			Model	Size	Ripple		Response		Certificates
Rated Voltage	Rated Current	Rated Power			Voltage	Current	Voltage increase	Voltage Drop	
20V	60A	600W	SP20VDC600W	1U ¹	40mVp-p/6mVrms	20mA (TYP Value)	≤10ms(No load), ≤10ms(Full load)	≤150ms(No load), ≤20ms(Full load)	CE/RoHs
		1000W	SP20VDC1000W					≤150ms(No load), ≤15ms(Full load)	CE/RoHs
		1200W	SP20VDC1200W					≤150ms(No load), ≤12ms(Full load)	CE/RoHs
32V	50A	600W	SP32VDC600W	1U ¹	40mVp-p/6mVrms	20mA (TYP Value)	≤12ms(No load), ≤12ms(Full load)	≤150ms(No load), ≤20ms(Full load)	CE/RoHs
		1000W	SP32VDC1000W					≤150ms(No load), ≤15ms(Full load)	CE/RoHs/CSA/FCC
		1200W	SP32VDC1200W					≤150ms(No load), ≤12ms(Full load)	CE/RoHs/CSA/FCC
	200A	1600W	SP32VDC1600W	1U ¹	60mVp-p/10mVrms	200mA (TYP Value)	≤20ms(No load), ≤40ms(Full load)	≤150ms(No load), ≤10ms(Full load)	CE/RoHs/CSA/FCC
		1000W	SPS32VDC1000W	2U ⁵				≤500ms(No load), ≤45ms(Full load)	CE
		2000W	SP32VDC2000W					≤20ms(No load), ≤30ms(Full load)	CE
		3000W	SP32VDC3000W					≤20ms(No load), ≤20ms(Full load)	CE/RoHs
40V	40A	600W	SP40VDC600W	1U ¹	40mVp-p/6mVrms	20mA (TYP Value)	≤10ms(No load), ≤10ms(Full load)	≤150ms(No load), ≤20ms(Full load)	CE/RoHs
		1000W	SP40VDC1000W					≤150ms(No load), ≤15ms(Full load)	CE/RoHs/CSA/FCC
		1200W	SP40VDC1200W					≤150ms(No load), ≤12ms(Full load)	CE/RoHs/CSA/FCC
	120A	1600W	SP40VDC1600W	1U ¹	40mVp-p/6mVrms	20mA (TYP Value)	≤10ms(No load), ≤10ms(Full load)	≤150ms(No load), ≤10ms(Full load)	CE/RoHs/CSA/FCC
		1000W	SPS40VDC1000W	2U ⁵				≤350ms(No load), ≤10ms(Full load)	CE/RoHs
		2000W	SP40VDC2000W					CE/RoHs	
		3000W	SP40VDC3000W					CE/RoHs	
75V	25A	600W	SP75VDC600W	1U ²	40mVp-p/6mVrms	10mA (TYP Value)	≤10ms(No load), ≤10ms(Full load)	≤160ms(No load), ≤20ms(Full load)	CE/RoHs/CSA
		1000W	SP75VDC1000W					≤160ms(No load), ≤15ms(Full load)	CE/RoHs/CSA/FCC
		1200W	SP75VDC1200W					≤160ms(No load), ≤12ms(Full load)	CE/RoHs/CSA/FCC
		1500W	SP75VDC1500W					≤160ms(No load), ≤10ms(Full load)	CE/RoHs/CSA/FCC
	60A	4000W	SP75VDC4000W	2U ⁴	40mVp-p/8mVrms	10mA (TYP Value)	≤15ms(No load), ≤15ms(Full load)	≤450ms(No load), ≤20ms(Full load)	CE/RoHs/CSA/FCC
80V	60A	1000W	SP80VDC1000W	2U ⁴	40mVp-p/6mVrms	10mA (TYP Value)	≤15ms(No load), ≤15ms(Full load)	≤450ms(No load), ≤30ms(Full load)	CE
		2000W	SP80VDC2000W					CE/RoHs	
		3000W	SP80VDC3000W					CE/RoHs	
120V	40A	1000W	SPS120VDC1000W	2U ⁴	80mVp-p/15mVrms	10mA (TYP Value)	≤20ms(No load), ≤20ms(Full load)	≤350ms(No load), ≤21ms(Full load)	CE/RoHs
		2000W	SP120VDC2000W					CE/RoHs/CSA/FCC	
		3000W	SP120VDC3000W					CE/RoHs/CSA/FCC	
		4000W	SP120VDC4000W					CE/RoHs	
150V	10A	600W	SP150VDC600W	1U ³	120mVp-p/40mVrms	10mA (TYP Value)	≤25ms(No load), ≤25ms(Full load)	≤400ms(No load), ≤32ms(Full load)	CE/RoHs
		1000W	SP150VDC1000W					CE/RoHs	
		1200W	SP150VDC1200W					CE/RoHs	
	30A	1500W	SP150VDC1500W	2U ⁴	80mVp-p/15mVrms	10mA (TYP Value)	≤25ms(No load), ≤25ms(Full load)	≤500ms(No load), ≤25ms(Full load)	CE/RoHs
		1000W	SPS150VDC1000W					CE/RoHs	
		2000W	SP150VDC2000W					CE/RoHs/CSA/FCC	
		3000W	SP150VDC3000W					CE/RoHs/CSA/FCC	
200V	8A	600W	SP200VDC600W	1U ³	120mVp-p/40mVrms	10mA (TYP Value)	≤30ms(No load), ≤30ms(Full load)	≤600ms(No load), ≤50ms(Full load)	CE/RoHs
		1000W	SP200VDC1000W					≤600ms(No load), ≤40ms(Full load)	CE/RoHs
		1200W	SP200VDC1200W					≤600ms(No load), ≤36ms(Full load)	CE/RoHs
		1500W	SP200VDC1500W					≤600ms(No load), ≤30ms(Full load)	CE/RoHs
	24A	1000W	SPS200VDC1000W	2U ⁴	150mVp-p/30mVrms	20mA (TYP Value)	≤30ms(No load), ≤30ms(Full load)	≤500ms(No load), ≤20ms(Full load)	CE/RoHs
		2000W	SP200VDC2000W					CE/RoHs	
		3000W	SP200VDC3000W					CE/RoHs	
600V	10A	1000W	SPS600VDC1000W	2U ⁵	350mVp-p/40mVrms	10mA (TYP Value)	≤60ms(No load), ≤60ms(Full load)	≤800ms(No load), ≤110ms(Full load)	CE/RoHs
		2000W	SP600VDC2000W					≤800ms(No load), ≤90ms(Full load)	CE/RoHs
		3000W	SP600VDC3000W					≤800ms(No load), ≤75ms(Full load)	CE/RoHs
		4000W	SP600VDC4000W					≤800ms(No load), ≤60ms(Full load)	CE/RoHs
800V	7.5A	1000W	SPS800VDC1000W	2U ⁵	800mVp-p/200mVrms	10mA (TYP Value)	≤60ms(No load), ≤60ms(Full load)	≤800ms(No load), ≤60ms(Full load)	CE/RoHs
		2000W	SP800VDC2000W					CE/RoHs	
		3000W	SP800VDC3000W					CE/RoHs	
		4000W	SP800VDC4000W					CE/RoHs	

PROGRAMMABLE DC POWER SUPPLY

High Power Programmable DC Power System



6U



20U



12U

Rated Voltage	Output		Model	Size	Certificates
	Rated Current	Rated Power			
32V	600A	12kW	SYS32VDC12000W	6U ^⑥	CE
	1200A	24kW	SYS32VDC24000W	12U ^⑦	
	2000A	40kW	SYS32VDC40000W	20U ^⑧	
40V	360A	12kW	SYS40VDC12000W	6U ^⑥	
	720A	24kW	SYS40VDC24000W	12U ^⑦	
	1200A	40kW	SYS40VDC40000W	20U ^⑧	
75V	180A	12kW	SYS75VDC12000W	6U ^⑥	
	360A	24kW	SYS75VDC24000W	12U ^⑦	
	600A	40kW	SYS75VDC40000W	20U ^⑧	
96V	200A	12kW	SYS96VDC12000W	6U ^⑥	
120V	120A	12kW	SYS120VDC12000W	6U ^⑥	
	240A	24kW	SYS120VDC24000W	12U ^⑦	
	400A	40kW	SYS120VDC40000W	20U ^⑧	
150V	90A	12kW	SYS150VDC12000W	6U ^⑥	
	180A	24kW	SYS150VDC24000W	12U ^⑦	
	300A	40kW	SYS150VDC40000W	20U ^⑧	
192V	200A	24kW	SYS192VDC24000W	12U ^⑦	
200V	72A	12kW	SYS200VDC12000W	6U ^⑥	
	144A	24kW	SYS200VDC24000W	12U ^⑦	
	240A	40kW	SYS200VDC40000W	20U ^⑧	

Rated Voltage	Output		Model	Size	Certificates
	Rated Current	Rated Power			
225V	60A	12kW	SYS225VDC12000W	6U ^⑥	CE
240V	120A	24kW	SYS240VDC24000W	12U ^⑦	
320V	200A	40kW	SYS320VDC40000W	20U ^⑧	
360V	40A	12kW	SYS360VDC12000W	6U ^⑥	
400V	120A	40kW	SYS400VDC40000W	20U ^⑧	
450V	30A	12kW	SYS450VDC12000W	6U ^⑥	
	60A	24kW	SYS450VDC24000W	12U ^⑦	
600V	30A	12kW	SYS600VDC12000W	6U ^⑥	
	60A	24kW	SYS600VDC24000W	12U ^⑦	
	100A	40kW	SYS600VDC40000W	20U ^⑧	
	720V	40A	24kW	SYS720VDC24000W	
750V	60A	40kW	SYS750VDC40000W	20U ^⑧	
800V	22.5A	12kW	SYS800VDC12000W	6U ^⑥	
	45A	24kW	SYS800VDC24000W	12U ^⑦	
	75A	40kW	SYS800VDC40000W	20U ^⑧	
900V	30A	24kW	SYS900VDC24000W	12U ^⑦	
1200V	24A	24kW	SYS1200VDC24000W	12U ^⑦	
	40A	40kW	SYS1200VDC40000W	20U ^⑧	

Dimensions & Weight



① 483x44x531mm & 9.2kg



② 483x44x531mm & 8.9kg



③ 483x44x531mm & 9.3kg



④ 483x87x581mm & 13.2kg



⑤ 483x87x626mm & 14.7kg



⑥ 600x700x696mm & 53.5kg+15kg*3(REF)



⑦ 600x700x963mm & 100kg+15kg*6(REF)



⑧ 600x700x1338mm & 120kg+15kg*10(REF)

PROGRAMMABLE DC POWER SUPPLY

Features

- Low ripple and noise
- High accuracy and high resolution
- CC and CV working mode switch freely
- Support LIST/SEQUENCE file editing
- OVP/OCP/OPP/OTP/SCP
- Remote compensation
- With external analog control input interface
- Standard USB/LAN/RS485/RS232 communication interface
- Master/Slave parallel and series operation mode for up to 10 units

Optional Information

GPIO communication card & cables

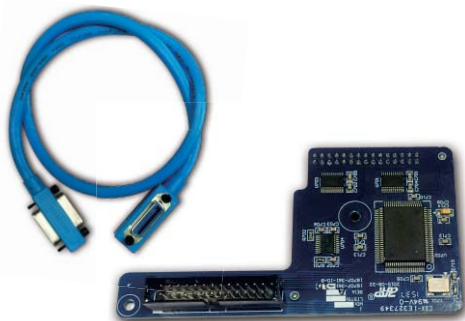

Three-core input cable (Input voltage range 176-265V, only supported on 1U height units)



SP Series Front Panel Introduction

1U Power Supply Front Panel



2U Power Supply Front Panel



Key	Introduction
0-9	Numeric Key
.	Decimal Point
Esc	Escape
▲	UP, used for choose menu or increase set value in menu operation
▼	DOWN, used for choose menu or decrease set value in menu operation
Enter	Enter
V-set	Set power supply's output voltage value
I-set	Set power supply's output current-limiting value

Key	Introduction
Display	Press it to back to the main interface quickly
On/Off	Control ON/OFF of power supply
Menu	Menu
Shift	Work with functional keys to realize multifunction
LOCAL	Panel operation
RECALL	Recall stored setting value of power supply from internal storage
STORE	Store current settings of power supply to storage location
DVM/POWER	Display DVM value and power value

PROGRAMMABLE DC POWER SUPPLY

SP Series Back Panel Introduction

1U Power Supply Back Panel

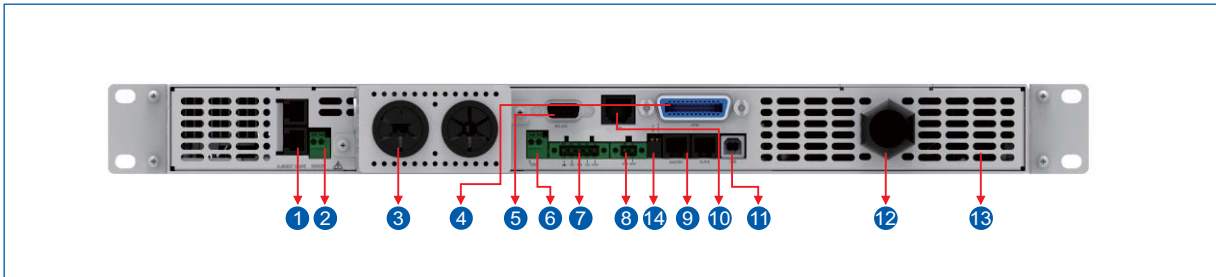

2U Power Supply Back Panel

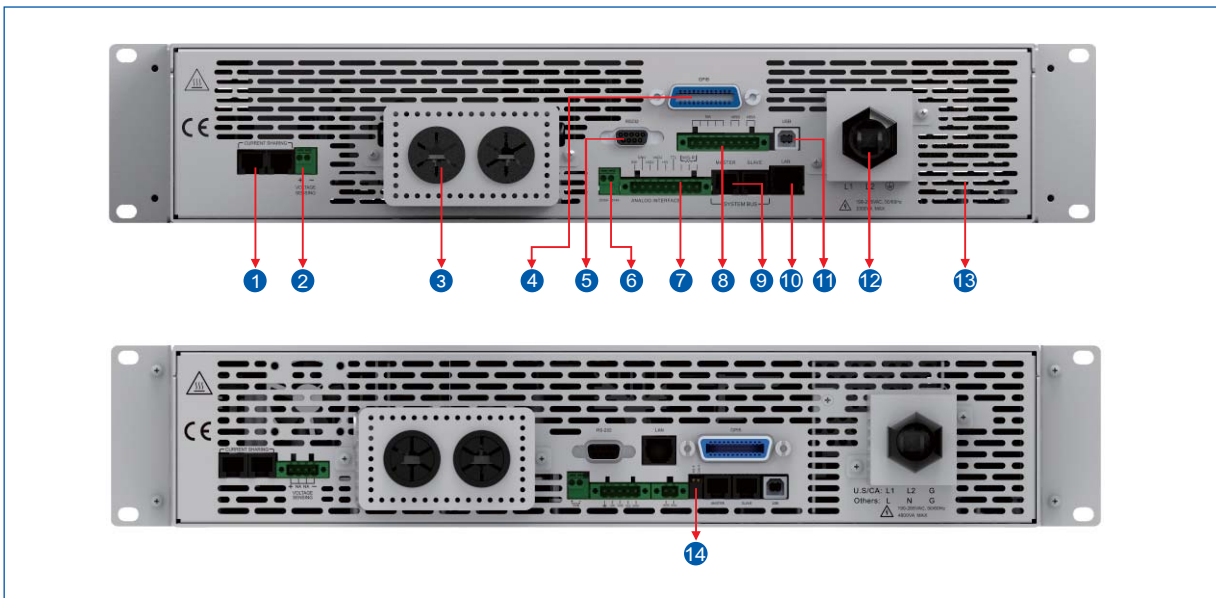

- 1 AVG1/AVG2 Connector, used for connecting between units to enable current sharing.
- 2 Voltage Remote Supporting Connector (VOLTAGE SENSING): Used to support wire voltage drops.
- 3 DC output terminal: Left (-), Right (+).
- 4 GPIB Communication connector.
- 5 RS-232 Communication connector.
- 6 DVM Connector.
- 7 ANALOG INTERFACE signal connection terminal.
- 8 RS-485 Communication connector.
- 9 SYSTEM BUS control, used for transmission of master and slaves.
- 10 LAN Communication Interface.
- 11 USB Communication Interface.
- 12 AC Power Connection terminal.
- 13 The fan duct outlet.
- 14 Termination resistor for RS485 and CAN Communication.

Note: There is a slight difference between these two kinds of rear panels of 2U units.

PROGRAMMABLE DC POWER SUPPLY

Ultra-low Voltage Mode

This function is applicable to cable/fuse current carrying capacity test, when activated, the power supply will shutdown the short circuit protection function and maintain ultra- low voltage to output rated current.

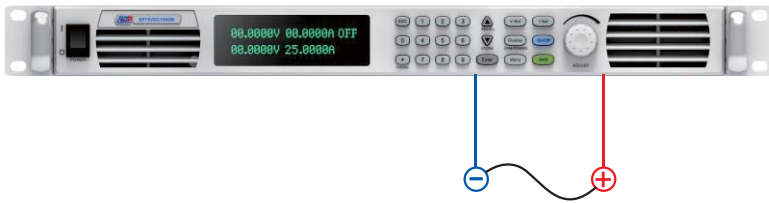

ADVANCED FUNC
SHORT MODE = 

Timer Control function

This function is applicable to unattended occasions, activate the timer and the output, the screen will show the countdown of the timer. Once it reaches down to zero, the supply will turn off the output automatically. And the full protection of the power supply will make sure the safe usage of this function.

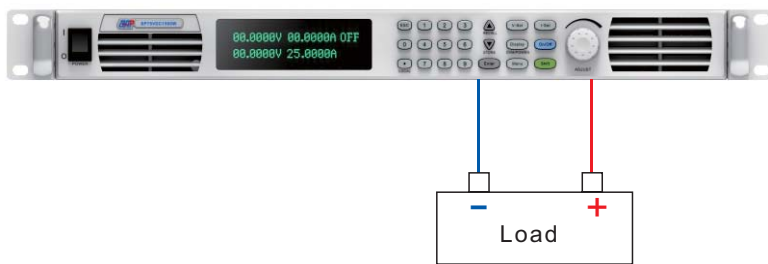

TIMER 00:05:00
00.0000V 000.000A OFF
12.0000V 009.000A

Remote Compensation Function

This function is applicable to compensate the voltage drop on the load line in order to improve the accuracy of test. In practical applications, even if the voltage drop is negligible, it is best to connect the remote compensation cable to the output terminal. When using the remote compensation functionality, please disconnect the S+, S- from the power supply's output terminal, and connect them to both ends of the DUT. Maximum compensation voltage is up to 5V. The output power need be lower than 1.05% of the rated power after compensation.

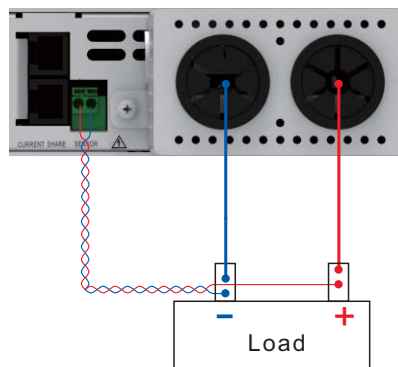

PROGRAMMABLE DC POWER SUPPLY

External Control Function

This series power supply can offer external voltage/ potentiometers control output, can be controlled by external voltage(0~5V) or external potentiometers(5~10K) in order to remotely adjust the power supply voltage and current regulation settings and the output status of the power supply.

External Voltage Control

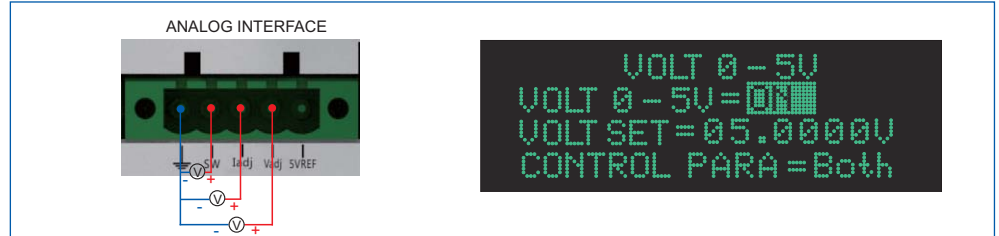

External Potentiometer Control



LIST Waveform Editing Function

This series power supply supports 3 kinds of LIST file editing format in order to meet the output elements of different test requirements. The minimum resolution of time setting is 1ms.

Impulse File Format

Sets the trend of the output voltage over time and its duration. Set the mode of the output waveform execution as required, LOOP, CONT, STEP.

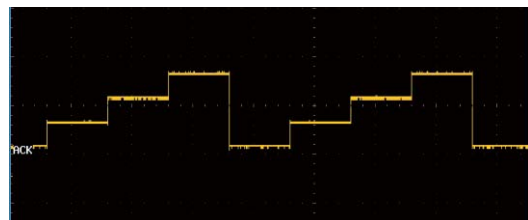
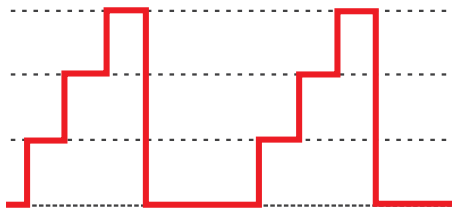

Slope File Format

Support to set the slope of output voltage, achieve to slowly increase and drop of the output voltage. Set the mode of the output waveform execution as required, LOOP, CONT, STEP.

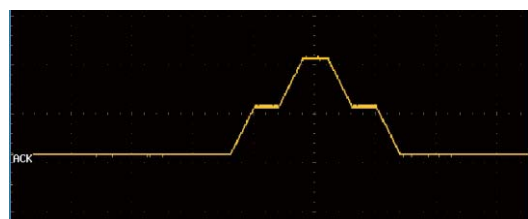
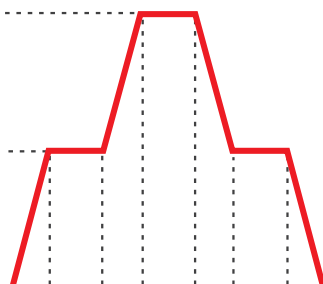

PROGRAMMABLE DC POWER SUPPLY

SEQUENCE Waveform Editing function

This function is an upgrade version of the LIST file editing. Its every step is a complete LIST file. It can combine several LIST file and output, meanwhile, it can set the number of repetitions per LIST file and number of executions of the entire SEQUENCE file.

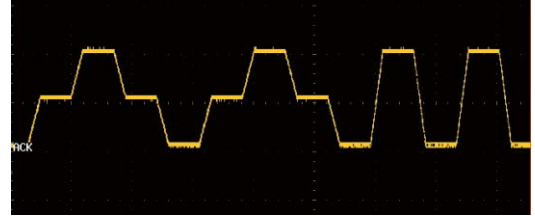

Measure Average Function

Under this mode, if the DUT has a sharp change in voltage and current, the averaging times can be adjusted to be FAST, MEDIUM or SLOW to make the displayed value more stable.

```
MEASURE AVERAGE
MEAS SPEED = FAST
```

Current Counting Function

This function offers testing of the cutoff time of a breaker or a fuse.

Starts timing when the current reaches the circuit breaker or fuse's fusing current I_b , stops timing when disconnected, the timing resolution is up to 200ms.

```
V=00.0000V I=00.0000A
Ib=10.0000A OFF
00:00:000ms
```

Quick Recall Function

Support to recall the stored parameters directly by the numeric keys on the front panel.

Firstly, user stores the frequently used data in the power supply's memory, press the numeric key directly after entering the quick recall mode, can quick recall the datas which are stored in 【1】 ~ 【9】

```
00.0000V 000.000A OFF
12.0000V 009.000A [1]
```

PROGRAMMABLE DC POWER SUPPLY

Master/Slave Mode

This series power supply support Master/Slave parallel and series operation mode for up to 10 units, extended power up to 40kW. The current sharing function in parallel mode realizes the equalization of the power supplies in the system, thereby ensuring the extended power without affecting the performance index of the power supply. CAN parallel mode realizes the same dynamic response of the system as single unit, realizing high-speed and non-delayed synchronous response of master and slave.

Parallel Connection

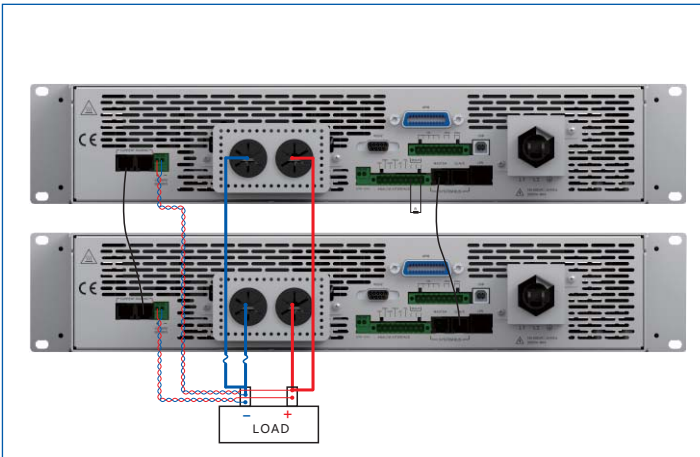

Series Connection

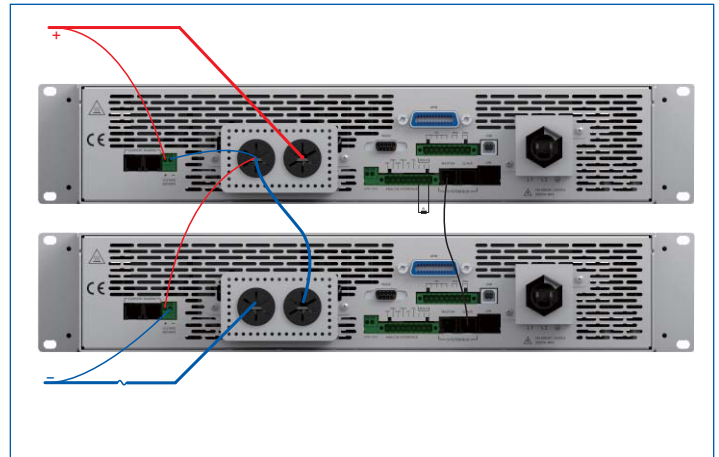

Positive / Negative Voltage Output Mode

This mode which enables both positive and negative outputs simultaneously in master slave operation.

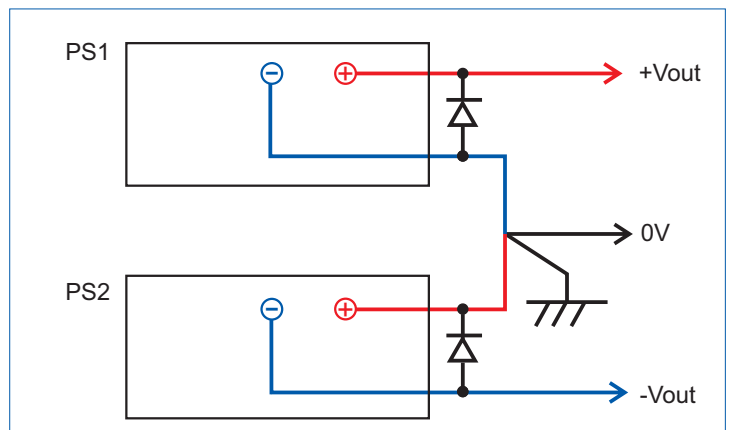
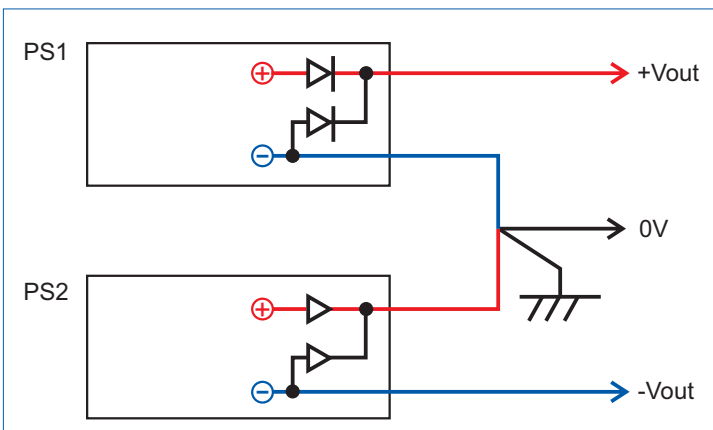
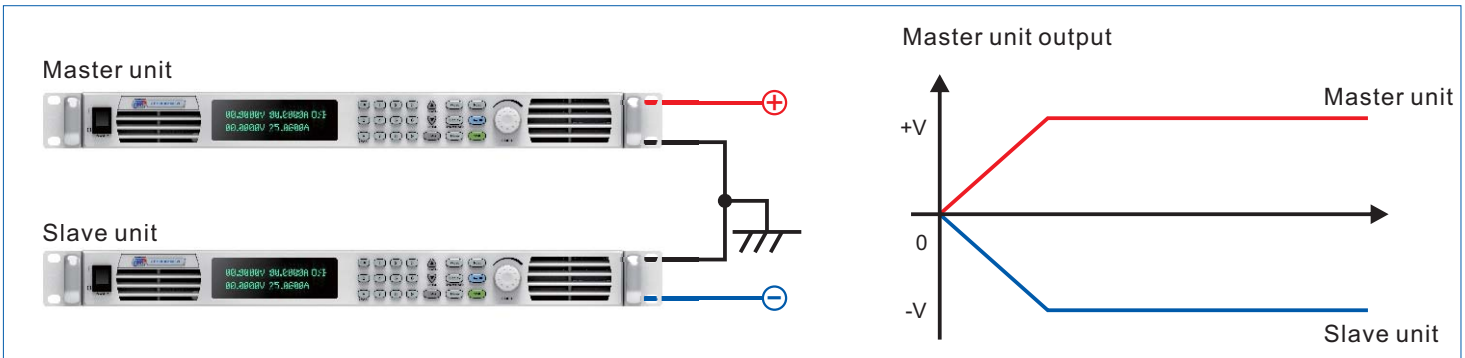

The power supply below 200A has been connected with anti reverse diode, so the external diode isn't needed in the actual connection, and the 200A power supply needs to connect the diode.

PROGRAMMABLE DC POWER SUPPLY

Built-in Standard Automobile Electric Test Waveform

It can be used to simulate the transient interference of power supply which may often be encountered in the process of automobile startup and operation. In accordance with industry standards, this series power supply has built-in voltage curves under the DIN40839 and ISO 16750-2 standards for 12V and 24V test grades. User can call the voltage curve directly for testing or edit as desired.

The built-in standard waveform outline and file names are as below:

No.	Standard	Test item name	Waveform	List/Sequence File Name(Built-in)
1	ISO16750-2	Automobile Start Transient Voltage Drop		List 3-2 (12V Voltage Grade) List 3-7 (24V Voltage Grade)
2	ISO16750-2	Automobile Electronic Restoration Function Test		Sequence1 (includes List 3-3 and List 3-4, for 12V system) Sequence 2 (includes List 3-8 and List 3-9, for 24V system)
3	ISO16750-2	Automobile Electronic Engine Start Test		List 3-5
4	DIN40839	Automobile Electronic Engine Start Test		List 3-1

Anti reverse irrigation/Power Sink Function

This series power supply has protection against reverse irrigation, so as to cut off the current of DUT in a certain test condition to the direction of power supply, and prevent the damage to the power supply hardware circuit from DUT.



Meanwhile, this series power supply comes standard with short circuit copper sheet, When the test requires the power supply to absorb the spike generated by DUT to ensure the safety of the operation, the short-circuit copper piece can be connected, and the energy is absorbed by the output capacitor inside the power supply and other circuits.



Note: Please consult your sales representative to get detailed information about anti reverse irrigation protection for power supply models above 200A.

PROGRAMMABLE DC POWER SUPPLY

Monitoring Software

All power supplies come standard with graphical monitoring software, which supports all communication interfaces and covers almost all functions of the power supply front panel operation. In the communication selection interface, users can select the communication interface and search for the connected power supply according to the actual connection.



When the communication port has only one power supply connection, it enters the Single Mode interface. Includes the basic settings of voltage and current and measurement function, and List waveform editing/ saved test data function.

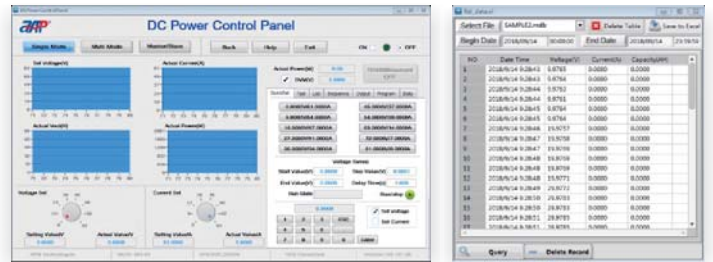

When the communication port has more than one power supply connection, it enters the Multi Mode interface. Supports switching control or display current power supply's settings.

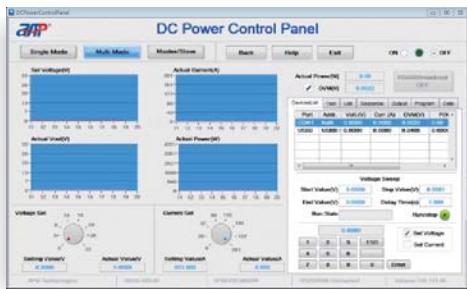

When the communication port connects the power supply that is the Master unit, it enters Master/Slave interface. The Master/Slave interface only maintains communication with the Master unit, and the parameters are synchronously written to the slaves.

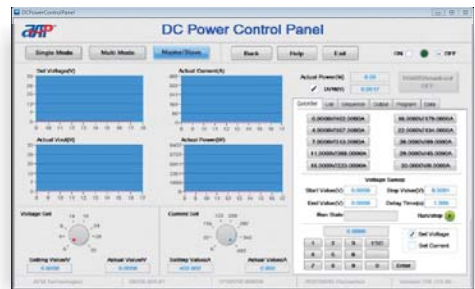

WebSever Function

Use can control the power supply on a computer using a web browser. No need to install the monitoring software, just open web browser and input IP address to control the unit, which can meet basic setting and monitoring requirements.



APM Technologies (Dongguan) Co., Ltd

Add: #7, Link Information Industry Park, Shuilianshan Road,
Nancheng, Dongguan, Guangdong, China

Tel: +86 769-2202 8588 ext:2892 Fax: +86 769-2202 6771

E-mail: overseas@apmtech.cn Web: en.apmtech.cn